

PRO DG
PROFESSIONAL DIGITAL GENERATION
SYSTEMS



GTA 1X12 L.A.

manual de uso
user manual

An updated .pdf version of this manual is always available at www.prodgsystems.com

Indicaciones de seguridad

Leer antes de usar el sistema y guardar para su uso posterior

Safety Indications

Please read it before use the system and keep for later use

PRO DG SYSTEMS® LE DA LAS GRACIAS POR HABER ADQUIRIDO ESTE SISTEMA DE SONIDO PROFESIONAL TOTALMENTE DISEÑADO, FABRICADO Y OPTIMIZADO EN ESPAÑA EXCLUSIVAMENTE CON COMPONENTES EUROPEOS Y LE DESEAMOS QUE DISFRUTE CON SU ALTA CALIDAD Y PRESTACIONES.

• El sistema ha sido diseñado, fabricado y optimizado por Pro DG Systems® en un estado técnicamente perfecto. Para conservar este estado y asegurar el correcto funcionamiento el usuario ha de respetar las siguientes indicaciones y advertencias de este manual.

LA FIABILIDAD, SEGURIDAD Y RENDIMIENTO DEL SISTEMA ESTAN UNICA Y EXCLUSIVAMENTE GARANTIZADAS POR PRO DG SYSTEMS CUANDO:

- El montaje, manipulación, reajuste y los cambios o reparaciones hayan sido realizados por Pro DG Systems.
- La instalación eléctrica cumpla con la determinación IEC (ANSI).
- El sistema se use según las indicaciones de uso.

ADVERTENCIA:

- Si se destapan protecciones o se retiran piezas del chasis, exceptuando las que se puedan retirar manualmente, se pueden dejar piezas al descubierto que sean conductoras de tensión.
- Cualquier ajuste, manipulación, optimización o reparación del sistema debe ser realizada única y exclusivamente por Pro DG Systems. PRO DG SYSTEMS NO SE RESPONSABILIZA DE NINGUN DAÑO QUE SUFRA EL SISTEMA A CAUSA DE UNA MANIPULACION, AJUSTE, OPTIMIZACION O REPARACION REALIZADA POR PERSONAL NO AUTORIZADO POR PRO DG SYSTEMS.
- Niveles elevados de intensidad de sonido pueden ser causa de daños auditivos se debe evitar acercarse demasiado a altavoces que funcionen a altos niveles, de lo contrario se deben usar protecciones auditivas.

ACOMETIDA A LA RED:

- El sistema está fabricado para un funcionamiento continuo.
- La tensión de funcionamiento ajustada tiene que coincidir con la tensión de la red del lugar.
- La conexión a la red eléctrica se efectuará con la fuente de alimentación o cable de red que se entreguen con el sistema.
- Fuente de alimentación: una línea de conexión dañada no se puede sustituir. La fuente de alimentación no se puede volver a poner en funcionamiento.
- Evite una conexión de la red eléctrica a distribuidores con muchas tomas de corriente.
- El enchufe para el suministro de corriente tiene que estar cerca del aparato y ser de fácil acceso.

SITUACION:

- El sistema debe situarse en una superficie limpia y totalmente horizontal.
- El sistema no puede estar expuesto a ninguna sacudida o movimiento durante su funcionamiento.
- Evite el contacto del sistema con el agua y superficies húmedas.
- Procure que el sistema disponga de la suficiente ventilación y no bloquee ni tape ninguna abertura de ventilación.
- Evite la exposición directa con el sol así como la proximidad a fuentes emisoras de calor o radiación.
- Si el sistema sufre un cambio extremo de temperatura es posible que afecte a su funcionamiento, antes de poner en marcha el sistema espere que éste haya adquirido la temperatura ambiental.

PRO DG SYSTEMS® GIVES YOU THANKS FOR ACQUIRE THIS PROFESSIONAL SOUND SYSTEM FULLY DESIGNED, MANUFACTURED AND OPTIMIZED IN SPAIN, EXCLUSIVELY WITH EUROPEAN COMPONENTS AND WE WISH THAT YOU ENJOY WITH ITS HIGH QUALITY AND PERFORMANCE.

• This system has been designed, fabricated and optimized by Pro DG Systems® in perfect working order. To maintain this condition and ensure the right operation, the user must respect the following indications and advices of this manual.

THE FIABILITY, SAFETY AND EFFICIENCY OF THE SYSTEM ARE ONLY AND EXCLUSIVELY GUARANTEED BY PRO DG SYSTEMS IF:

- Assembly, manipulation, re-adjustment and modifications or repairs are carried out by Pro DG Systems.
- The electrical installation complies with the requirements of IEC (ANSI).
- The system is used according to the use indications.

WARNING:

- If protectors are opened or sections of chassis are removed, except where this can be done manually, live parts can become exposed.
- Any adjustment, manipulation, optimization or reparation of the system must be done only and exclusively by Pro DG Systems. PRO DG SYSTEMS IS NOT RESPONSIBLE OF ANY DAMAGE OF THE SYSTEM CAUSED BY A MANIPULATION, ADJUSTMENT, OPTIMIZATION OR REPARATION REALIZED BY NO-AUTHORIZED PERSONAL BY PRO DG SYSTEMS
- High loudspeaker levels can cause hearing damage, it must avoid the direct contact with loudspeakers operating at high levels, otherwise it must use hearing protectors.

MAINS CONNECTION:

- The system is designed for continuous operation.
- The set operating voltage must match the local mains supply voltage.
- The units has to be connected to the mains via the supplied power unit or power cable.
- Power unit: never use a damaged connection lead. Any type of damage must be fixed.
- Avoid connection to the mains supply in distributor boxes together with several other power consumers.
- The plug socket for the power supply must be positioned near the unit and must be easily accessible.

PLACE OF SITUATION:

- The system should stand only on a clean and totally horizontal surface.
- The system must not be exposed to any type of vibration during its operation.
- Avoid the contact with the water or wet surfaces. Do not place objects containing liquid on the system.
- Procure that the system has sufficient ventilation and do not block or cover any ventilation opening. Obstruct the ventilation may cause overheating in the system.
- Avoid the direct exposition with the sun and proximity with sources of heat or radiation.
- If the system undergoes an extreme change in temperature may affect its operation, before starting the system hope it has reached room temperature.

Indicaciones de seguridad

Leer antes de usar el sistema y guardar para su uso posterior

Safety Indications

Please read it before use the system and keep for later use

ACCESORIOS:

- El sistema no debe colocarse encima de ningún soporte inestable que pueda causar daños personales o al sistema coloque el sistema sólo en un carro, rack, trípode, soporte recomendado o suministrado por Pro DG Systems siguiendo las indicaciones de instalación. El conjunto del sistema con el pedestal se debe mover con mucho cuidado. La aplicación de una fuerza desmesurada o un suelo irregular puede ocasionar la caída de todo el conjunto.
- Piezas adicionales: no utilice nunca piezas adicionales que no estén recomendadas por Pro DG Systems. El uso de piezas no recomendadas puede provocar accidentes y rotura del sistema.
- Para proteger el sistema de una tormenta o si éste no se supervisa o utiliza durante algún tiempo, se debe desconectar la clavija de la red. Así se evitan daños en el sistema a causa de un rayo y golpes de tensión en la red de corriente alterna.

SE RECOMIENDA AL USUARIO LEER ESTAS INSTRUCCIONES ANTES DE USAR EL SISTEMA Y GUARDAR PARA SU USO POSTERIOR.

PRO DG SYSTEMS NO SE RESPONSABILIZA DEL USO INADECUADO DEL SISTEMA POR PARTE DE PERSONAL NO AUTORIZADO SIN LOS SUFICIENTES CONOCIMIENTOS DE USO.

EL USO DE LOS PRODUCTOS PRO DG SYSTEMS ESTA INDICADO PARA LOS PROFESIONALES AUTORIZADOS QUE DEBEN POSEER LOS SUFICIENTES CONOCIMIENTOS DE USO DEL MISMO Y SIEMPRE RESPETANDO LAS INDICACIONES QUE SE MUESTRAN A CONTINUACION EN ESTE MANUAL.

ACCESSORIES:

- Do not place the system on a unsteady base that can be cause of damage to people or to the system, use it only with the trolley, rack, tripod or base recommended or supplied by Pro DG Systems following the installation indications. The system's combination must be moved very carefully.
- The application of an excessive use of force and uneven floors can cause the combination of system and stand to tip over.
- Additional equipment: don't use additional equipment wich has not be recommended by Pro DG Systems. The use of not recommended equipment can cause accidents and damage to the system.
- To protect the system during bad weather or when left unattended for prolonged periods, the main plug should be disconnected. This prevents the system being damaged by lightning and power surges in the AC mains supply.

IT IS RECOMMENDED TO THE USER READ THESE INSTRUCTIONS BEFORE USING THE SYSTEM AND SAVE FOR LATER USE.

PRO DG SYSTEMS IS NOT RESPONSIBLE OF AN INADEQUATE USE OF THE SYSTEM BY NO-AUTHORIZED PERSONNEL WITHOUT ENOUGH KNOWLEDGE OF USE.

THE USE OF THE PRO DG SYSTEMS PRODUCTS IS INDICATED FOR AUTHORIZED PROFESSIONALS THAT MUST TO HAVE ENOUGH KNOWLEDGE OF THE SYSTEM USE AND ALWAYS RESPECTING THE INDICATIONS SHOWED BELOW.



Pro DG Systems GTA 1X12 L.A.

Manual de uso - User manual

- I. **GTA 1X12 L.A. Introducción / Introduction.**
 - I.I. Descripción / **Description.** Pág. 1
 - I.II. Especificaciones Técnicas & Arquitecturales / **Technical & Architectural Specifications.** Pág. 2

- II. Interior del **GTA 1X12 L.A. / Inside the GTA 1X12 L.A.**
 - II.I. Características principales del Altavoz - Especificaciones Técnicas - Parámetros - Información de montaje / **Speaker Key Features - Technical Specifications - Thiele - Small Parameters - Mounting information.** Pág. 3
 - II.II. Características principales de la Bocina de directividad constante del **GTA 1X12 L.A. / Features of the GTA 1X12 L.A. Constant Directivity Horn** Pág. 4
 - II.III. Motores de compresión **GTA 1X12 L.A.** Características principales (1 unidad) - Drivers de frecuencia & Curvas de distorsión - Curva de Impedancia - Dispersión Horizontal - Dispersión Vertical - Características técnicas - Dimensiones - Información de montaje - Materiales de construcción / **GTA 1X12 L.A. Compression Drivers. Key Features (1 unit) - Frequency Drivers & Distortion Curves - Impedance Curve - Horizontal & Vertical Dispersion - Technical Specifications - Dimensions Graph - Mounting information - Construction Materials** Pág. 5-6

- III. Amplificación de **GTA 1X12 L.A. / GTA 1X12 L.A. Amplification**
 - III.I. **GT 1.2 H** Especificaciones Técnicas / **GT 1.2 H Technical Specifications.** Pág. 7-8

IV.	Accesorios de montaje / Rigging Hardware	
	IV.I. Hardware de Vuelo / Flight Hardware	Pág. 9
V.	Software de Predicción / Prediction Software	Pág. 10
VI.	Equipamiento y Accesorios / Equipment and Accessories	Pág. 11

I. INTRODUCCION - INTRODUCTION

Este manual ha sido diseñado para ayudar a los usuarios del sistema: **GTA 1X12 L.A.** de **Pro DG Systems** a la correcta utilización y al entendimiento de los beneficios y versatilidades del mismo. **GTA 1X12 L.A.** es un sistema Line array autoamplificado totalmente diseñado, fabricado y optimizado en Europa (España), exclusivamente con los mejores componentes Europeos.

This manual is designed to help: **GTA 1X12 L.A.** system users from **Pro DG Systems**, to the correct use and for the understanding of the benefits and versatilities of the same. **GTA 1X12 L.A.** is a self-powered Line array system totally designed, manufactured and optimized in Europe (Spain), exclusively with the best European components.



GTA 1X12 L.A.

100% diseñado, fabricado y optimizado en Europa (España) exclusivamente con componentes Europeos.

100% designed, fabricated and optimized in Europe (Spain) exclusively with European components.

I.I. DESCRIPCION - DESCRIPTION

Es un sistema Line array autoamplificado de dos vías, equipado con un altavoz de 12" en un recinto sintonizado. La sección de agudos cuenta con tres drivers de compresión de 1" acoplados a una guía de onda.

La configuración del transductor, genera una cobertura horizontal simétrica de 90° sin lóbulos secundarios sobre el rango de frecuencia. Ideal para P.A. principal, Frontfill, Sidefill y Downfill tanto para conciertos en directo al aire libre como en instalación permanente.

Self-powered Line array system of 2-ways equipped with one (1) speaker of 12" in a tuning enclosure. The tweeter section has three (3) compression drivers of 1" coupled to a wave guide.

The transducer configuration, generates a symmetric and horizontal dispersion of 90 degrees, without secondary lobes over the frequency range. Ideal for main P.A. Sidefill, Frontfill and Downfill in outdoor events and permanent installation.



I.II. ESPECIFICACIONES - SPECIFICATIONS

Power Handling:	650 W RMS (EIA 426A Standard) programme of 1300 W / 2600 W peak.
Nominal Impedence:	Mid 8 Ohm / High 24 Ohm.
Average Sensitivity:	100 dB / 2.83 V / 1m (average of 100-16000 Hz wideband).
Calculated Maximum SPL:	/ 1m 128 dB continuous / 131 dB programme / 134 dB peak.
Frequency response:	(-6 dB) 80 Hz - 20 KHz.
Operative Frequency Range	+ /- 3 dB from 80 to 20000 Hz
Nominal Directivity:	90° degrees horizontal, vertical dispersion depends on longitude or personalized configuration.
Low / Mid Frequency Driver:	One Beyma speaker with 12", 8 Ohm, 500 W 312 mm (3") of diameter with high temperature glass fiber voice coil.
Mid Frequency Cut-off:	Without subwoofer: 60 Hz Butterworth 24 filter - 1200 Hz Linkwitz-riley 24 filter. With subwoofer system (IT 218 F-2000, GT 118 B or GT 218 B): 100 Hz Butterworth 24 filter - 1200 Hz Linkwitz-riley 24 filter.
High Frequency Driver:	three (3) Beyma drivers of 1", 8 Ohm, 50 W, 25mm exit (44.4mm) with diaphragm voice coil.
High Frequency Cut-off:	Without subwoofer: 1200Hz Linkwitz-riley 24 filter - 18000Hz Linkwitz-riley 24 filter With subwoofer system (IT 218 F-2000, GT 118 B or GT 218 B): 1200Hz Linkwitz-riley 24 filter - 18000 Hz Linkwitz-riley 24 filter.
Recommended Amplifier:	Pro DG systems GT 1.2 H into the Cabinet.
Connectors:	2 X XLR + 1 NL4MP speakon connectors. USB-Ethernet + 2 X Powercom.
Acoustic Box:	CNC model, 15mm made from birch wood plated on the exterior.
Finish:	Standard black paint job.
Box Dimensions:	(HxWxD) 370x580x445mm (14.57"x22.84"x17.52").
Weight:	35,4 Kg (78.04 lbs) net / 36.8 Kg (81.13 lbs) gross weight with packing materials.

ARCHITECTURAL SPECIFICATIONS

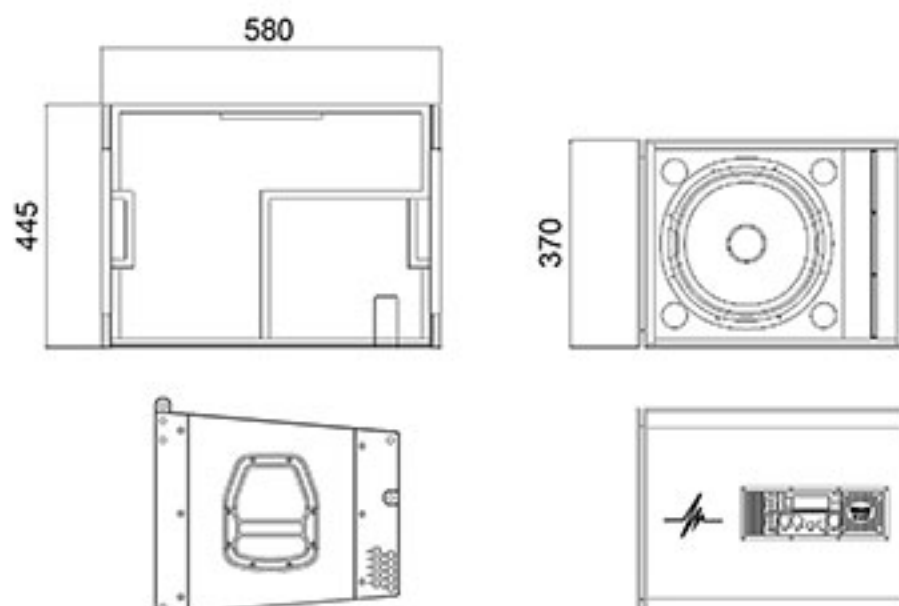

II. INTERIOR DEL GTA 1X12 L.A. - INSIDE THE GTA 1X12 L.A.

El interior del GTA 1X12 L.A. está compuesto por un altavoz Beyma de 12" 500 W RMS. Especialmente diseñado bajo nuestros propios parámetros para el mejor rendimiento del sistema.

Inside the GTA 1X12 L.A. is composed by one Beyma speaker of 12", 500 W RMS. Specially designed under our own parameters for the best performance of the system.

KEY FEATURES

- High power handling (500 W RMS).
- 3" (77 mm) copper voice coil with apical former.
- Optimum winding length for increase linear excursion.
- Extended response in the medium frequency range.
- Designed for high power woofer applications.

TECHNICAL SPECIFICATIONS

Nominal diameter	300 mm	8 in
Rated impedance		8 Ω
Minimum impedance		7,7 Ω
Power capacity		500 W RMS
Program power		1000 W
Sensitivity	96,2 dB	2,83v @ 1m @ 2π
Frequency range		35 - 4.000 Hz
Recom. enclosure vol.	30 / 100 l	1,06 / 3,53 ft ³
Voice coil diameter	77 mm	3 in
Magnetic assembly weight	4,9 kg	10,8 lb
BI factor		15,1 N/A
Moving mass		0,059 kg
Voice coil length		17,5 mm
Air gap height		7 mm
X _{damage} (peak to peak)		30 mm



Especialmente diseñado bajo nuestros propios parámetros para el mejor rendimiento del sistema.

Specially designed under our own parameters for the best performance of the system.

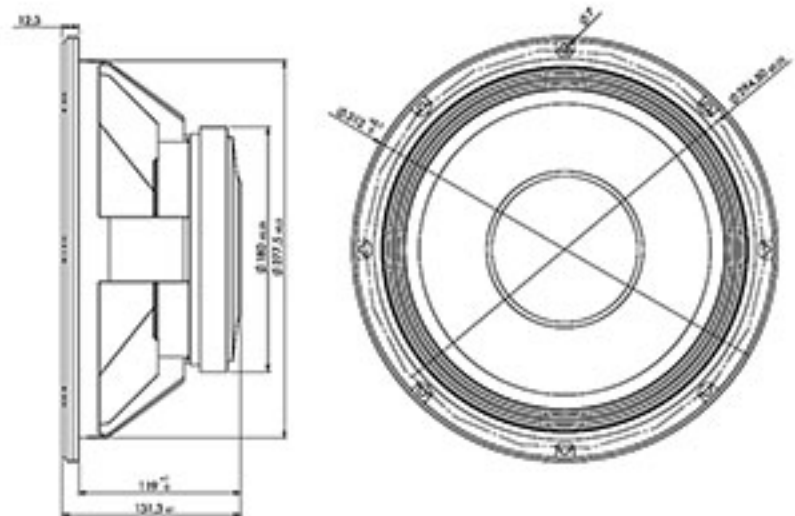

THIELE - SMALL PARAMETERS*

Resonant frequency, f_s	43 Hz
D.C. Voice coil resistance, R_e	6,2 Ω
Mechanical Quality Factor, Q_{ms}	12,43
Electrical Quality Factor, Q_{es}	0,45
Total Quality Factor, Q_{ts}	0,44
Equivalent Air Volume to C_{ms} , V_{as}	94,24 l
Mechanical Compliance, C_{ms}	223 μm / N
Mechanical Resistance, R_{ms}	1,32 kg / s
Efficiency, η_0	1,65 %
Effective Surface Area, S_d	0,055 m ²
Maximum Displacement, X_{max} **	7,25 mm
Displacement Volume, V_d	300 cm ³
Voice Coil Inductance, L_e @ 1 kHz	1,7 mH

MOUNTING INFORMATION

Overall diameter	312 mm	12,3 in
Bolt circle diameter	294,5 mm	11,6 in
Baffle cutout diameter:		
- Front mount	277,5 mm	10,9 in
- Rear mount	280 mm	11 in
Depth	138 mm	5,43 in
Volume displaced by driver	4,5 l	0,16 ft ³
Net weight	5,65 kg	12,45 lb

* T-S parameters are measured after an exercise period using a preconditioning power test. The measurements are carried out with a velocity-current laser transducer and will reflect the long term parameters (when the loudspeaker has been working a short time).

** The X max is calculated as: $(L_{vc} - H_{ag}) / 2 + (H_{ag} / 3,5)$, where L_{vc} is the voice coil length and H_{ag} is the air gap height.

INTERIOR DEL GTA 1X12 L.A. - INSIDE THE GTA 1X12 L.A.

GTA 1X12 L.A. está compuesta además por una bocina de directividad constante, específicamente diseñada para trabajar con tres motores de compresión Pro DG Systems de 50 W RMS, acoplados a una guía de ondas. Las características de directividad constante de este modelo, aseguran poder cubrir: 90° de amplitud horizontal y 20° de amplitud vertical en prácticamente cualquier frecuencia dentro de su radio de acción. Para garantizar la libertad de resonancia está construido en madera con acabado de frente plano que facilita el montaje empotrado.

GTA 1X12 L.A. is also composed by one constant directivity horn, specifically designed to work with three (3) Pro DG Systems compression drivers of 50 W RMS coupled to a waveguide. The constant directivity characteristics of this model ensure the ability to cover 90° wide horizontally and 20° wide vertically, at virtually any frequency within its operational range. To ensure freedom of resonance is constructed of wood with flat front finish to facilitate flush mounting.

KEY FEATURES

- Designed to be used with three Pro DG Systems compression drivers of 50 W RMS to a waveguide
- Provides uniform response
- Coverage of 90° in the horizontal plane and 20° in the vertical plane
- Precise directivity control in the pass band
- Wood construction with flat front to facilitate flush mounting



TECHNICAL SPECIFICATIONS

- **Horizontal beamwidth** 90° (+22°, -46°)
(-6 dB, 1.2 - 16 kHz)
- **Vertical beamwidth** 20° (+27°, -15°)
(-6 dB, 2 - 16 kHz)
- **Directivity factor (Q)** 60 (average 1.2 - 16 kHz)
- **Directivity index (DI)** 15.5 dB (+7 dB, -8.1 dB)
- **Cutoff frequency** 800 Hz
- **Dimensions (WxHxD)** 170x343x50(65)mm.
6.69x13.5x1.97(2.56) in.
- **Net weight** 0.75 kg / 1.65 lb.
- **Construction:** Wood.

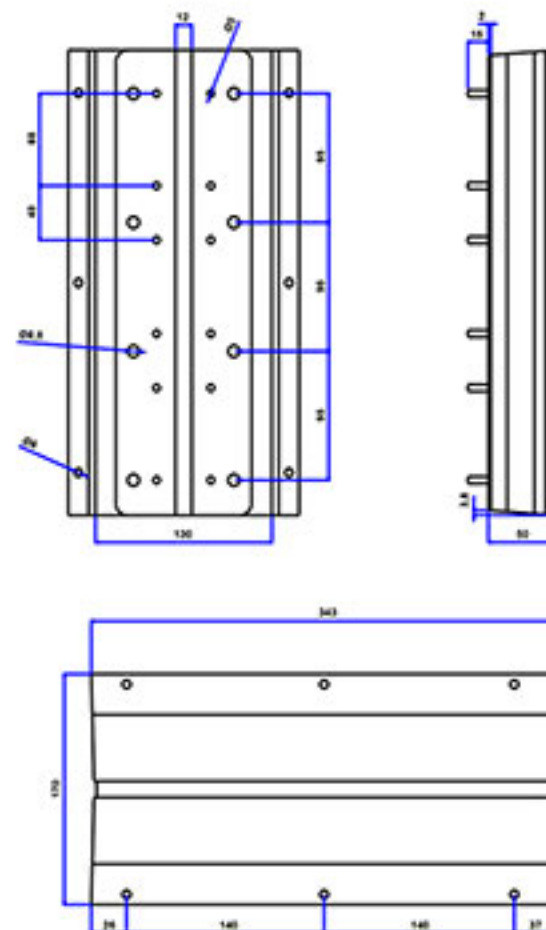

INTERIOR DEL GTA 1X12 L.A. - INSIDE THE GTA 1X12 L.A.

GTA 1X12 L.A. está compuesta además por tres motores de compresión Beyma de 50 W RMS, acoplados a una guía de onda. Especialmente diseñados bajo nuestros propios parámetros para el mejor rendimiento del sistema.

Una combinación de motor de compresión de neodimio de alta potencia con la guía de onda proporciona la mejor combinación para el mejor desempeño de GTA 1X12 L.A. resolviendo el difícil problema de lograr un acoplamiento óptimo entre transductores de alta frecuencia adyacentes. En lugar de utilizar los dispositivos de conformación de onda caros y complicados, una guía de onda simple pero eficaz transforma la abertura circular del controlador de compresión en una superficie rectangular y sin ángulo de abertura excesiva para proporcionar baja curvatura de onda acústica, cumpliendo con el requisito de curvatura, para un óptimo acoplamiento acústico entre las fuentes adyacentes hasta 18 KHz. Esto se logra con la longitud mínima posible de baja distorsión pero sin ser demasiado corta, lo que provocaría fuertes interferencias de alta frecuencia.

GTA 1X12 L.A. is composed in addition by three (3) Beyma compression drivers of 50 W RMS, coupled to a wave guide. Specially designed under our own parameters for the best performance of the system.

A combination of high power neodymium compression driver with waveguide, provides the best junction for the best performance of GTA 1X12 L.A. Solving the hard problem of achieving an optimum coupling between adjacent high frequency transducers. Instead of using expensive and troublesome wave - shaping devices, a simple but effective waveguide transforms the circular aperture of the compression driver into a rectangular surface, without undue angle aperture to provide low curvature to the acoustic wavefront, arriving to fulfil the necessary curvature requirement for the optimal acoustic coupling joint between adjacent sources until 18 KHz. This is achieved, with the minimum possible length for low distortion, but without being excessively short, which would cause strong high frequency interferences.

KEY FEATURES (ONE UNIT)

- 4" x 0.5" rectangular exit
- Neodymium magnetic circuit for high efficiency.
- Effective acoustical coupling up to 18 kHz.
- True 105 dB sensitivity 1w @ 1m (averaged 1-7 kHz).
- Extended frequency range: 0.7 - 20 kHz.
- 1.75" voice coil with a power handling of 50 W RMS.



FREQUENCY DRIVERS & DISTORTION CURVES

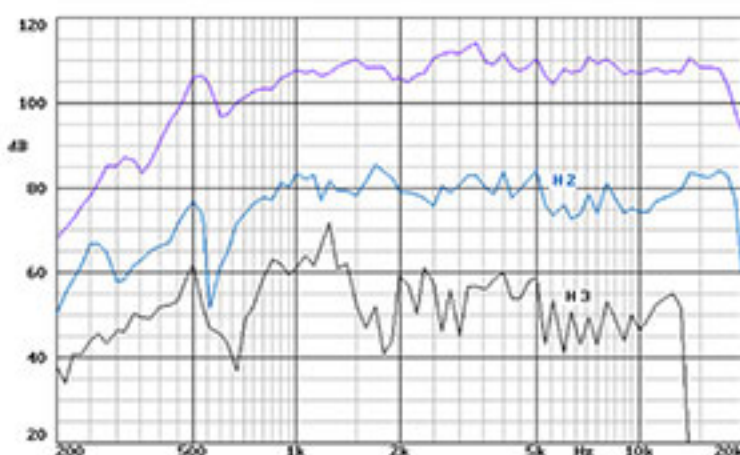

Note: on axis frequency response measured with 2 waveguides coupled to a 90° X 5° horn in an anechoic chamber, 1 w @ 1 m.

FREE AIR IMPEDANCE CURVE

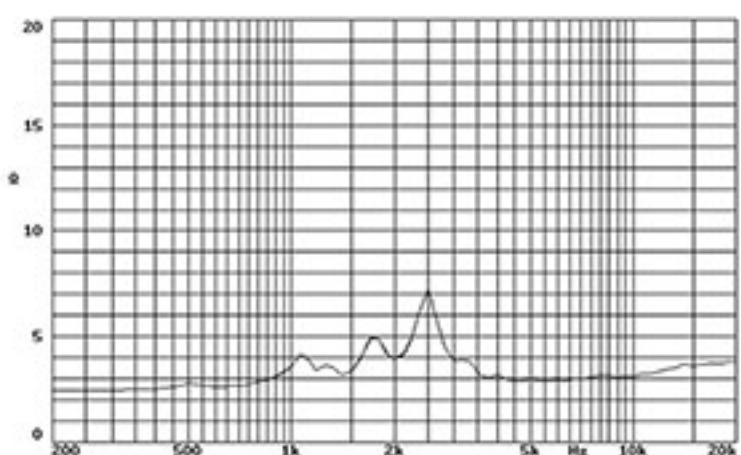

INTERIOR DEL GTA 1X12 L.A. - INSIDE THE GTA 1X12 L.A.

HORIZONTAL DISPERSION

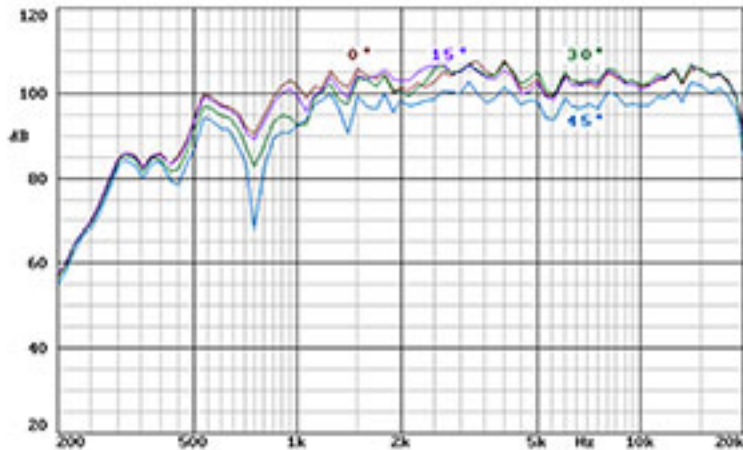

Notes: dispersion measured with two waveguides coupled to a 90° x 5° horn in anechoic chamber, 1w @ 2m.
All angle measurements are from the axis (45° means + 45°).

VERTICAL DISPERSION

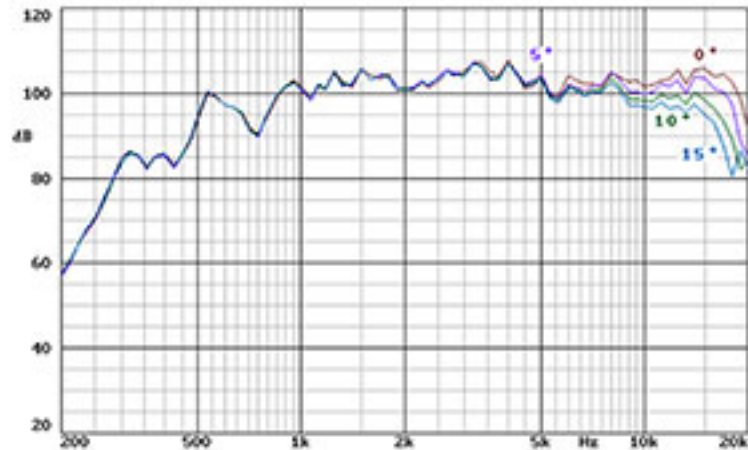

Notes: dispersion measured with two waveguides coupled to a 90° x 5° horn in anechoic chamber, 1w @ 2m.
All angle measurements are from the axis (45° means + 45°).

TECHNICAL SPECIFICATIONS

Throat diameter	20.5 mm. 0.8 in.
Rated impedance	8 ohms.
Minimum impedance	5.5 ohms. @ 4.5 kHz
D.C. Resistance	5.6 ohms.
Power capacity	50 W RMS above 1.5 kHz
Program power	100 W above 1.5 kHz
Sensitivity *	105 dB 1 w @ 1m coupled to a 90° x 5° horn
Frequency range	0.7 - 20 kHz
Recommended crossover	1500 Hz or higher (12 dB/oct. min.)
Voice coil diameter	44.4 mm. 1.75 in.
Magnetic assembly weight	0.6 kg. 1.32 lb.
Flux density	1.8 T
BL factor	8 N/A

DIMENSION DRAWINGS

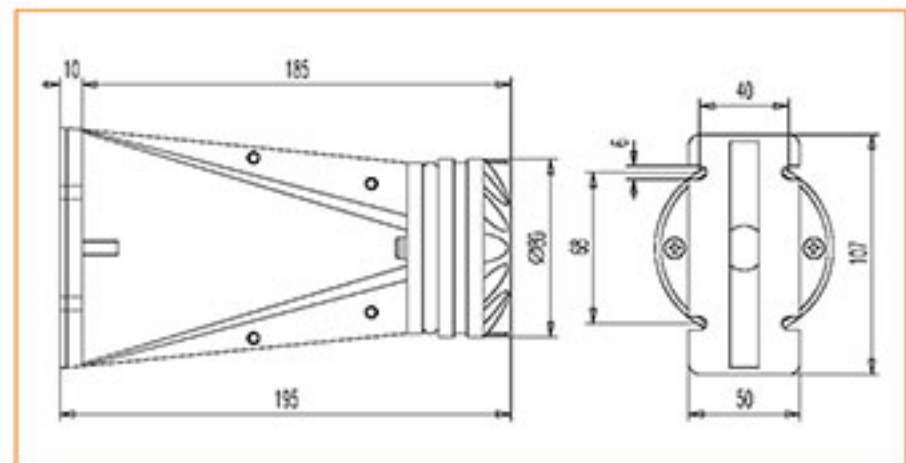

Note: * Sensitivity was measured at 1 m distance, on axis, with 1 w input, averaged in the range 1-7 KHz

MOUNTING INFORMATION

Overall diameter	80 mm. 3.15 in.
Depth	195 mm. 7.68 in.
Mounting	Four 6 mm. diameter holes
Net weight (1 unit)	1.1 kg. 2.42 lb.
Shipping weight (2 units)	2.6 kg. 5.72 lb.

CONSTRUCTION MATERIALS

- Waveguide: aluminium.
- Driver diaphragm: polyester.
- Driver voice coil: edgewound aluminium ribbon wire.
- Driver voice coil former: kapton.
- Driver magnet: neodymium.

III. AMPLIFICACION DEL GTA 1X12 L.A. / **GTA 1X12 L.A.** **AMPLIFICATION**

GT 1.2 H es un módulo amplificador digital de última generación Clase D de dos canales, 600 W por canal @ 4 Ω. Incorpora procesador digital con entrada y salida XLR + conector USB y Ethernet.

Ideal para realizar diferentes configuraciones entre sistemas y múltiples aplicaciones.

GT 1.2 H is a digital amplifier module last generation Class D of two (2) channels of 600 W @ 4 Ω. Includes digital processor with XLR input and output + USB and Ethernet connectors.

Ideal for different configurations between systems and multiple applications.



TECHNICAL SPECIFICATIONS

Output power per channel:	2 X 350 W @ 8 Ω - 2 X 600 W @ 4 Ω. Output power bridge mode 1200 W @ 4 Ω
Output Circuitry:	UMACTM Class D - full bandwidth PWM modulator with ultra low distortion
Output Voltage:	70 Vp / 140 Vpp (unloaded) / Bridged 140 Vp / 280 Vpp (unloaded)
Amplifier Gain:	26 dB
Signal To Noise-Ratio:	> 119 dB (A-weighted, 20 Hz - 20 kHz, 8 Ω load)
THD + N (typical):	< 0,05 % (20 Hz - 20 kHz, 8 Ω load, 3 dB below rated power)
Frequency Response:	20 Hz - 20 kHz ± 0.15 dB (8 Ω load, 1 dB below rated power)
Damping Factor:	> 900 (8 Ω load, 1 kHz and below)

Protection Circuits:	Short circuit protection, DC protection, under voltage protection, temperature protection, overload protection
Readouts for DSP / Network:	Protect/Disable (mute) Heatsink temperature Clip (each channel)
Power Supply:	UREC™ universal mains switch mode power supply with Power Factor Correction (PFC) and integral standby converter
Operation Voltage:	Universal Mains, 85 - 265 V Aux. Power for DSP ± 15 V (100 mA), + 7.5 V (500 mA)
Standby Consumption:	< 1 W (Green Energy Star compliant)
Dimensions (HxWxD):	106 x 296 x 105 mm / 4.17 x 11.65 x 4,13 in
Weight:	1,28 kg / 2,82 lbs

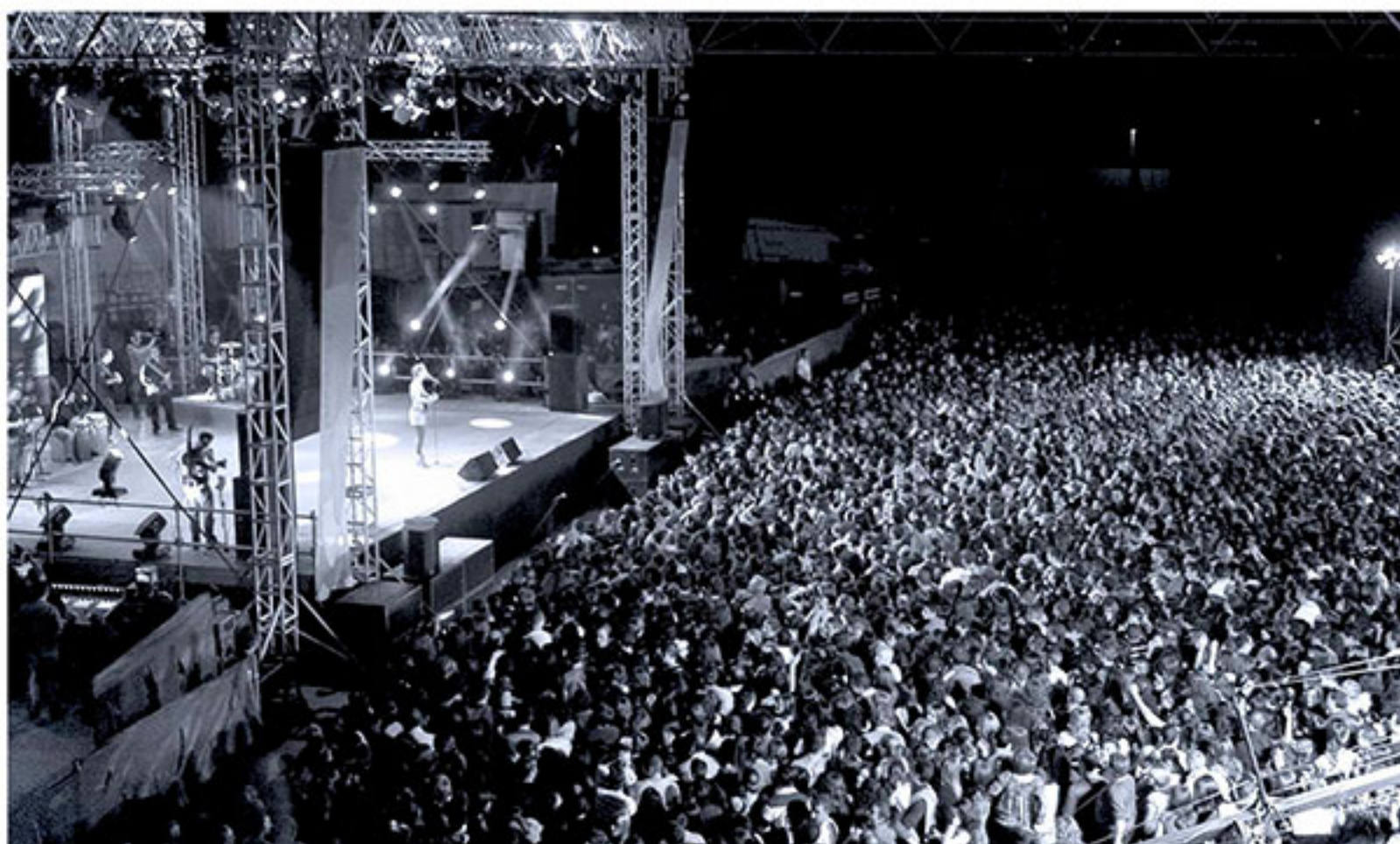

IV. HARDWARE DE VUELO - RIGGING HARDWARE



Hardware de vuelo para GTA 1X12 L.A. compuesto por: un marco de acero ligero + 4 pinlock + un grillete para soportar un peso máximo de dos toneladas. Permite elevar hasta un total de 16 unidades del GTA 1X12 L.A.

Rigging Hardware frame for GTA 1X12 L.A. composed by: one (1) lightweight steel frame + four (4) pinlock + one (1) shackle for support a maximum weight of two tons. Allowing elevate up a total of 16 GTA 1X12 L.A. units.

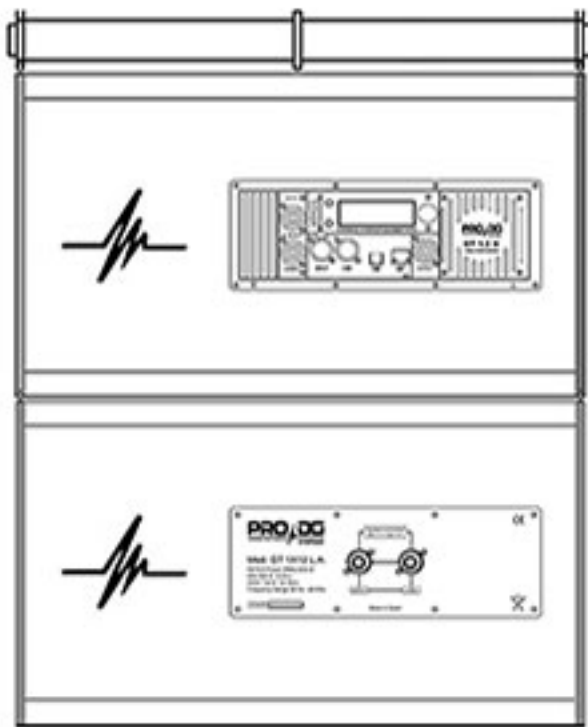

Hardware de vuelo incorporado en la caja con diferentes grados de angulación / Flight Hardware incorporated into the cabinet with different angulation grades.

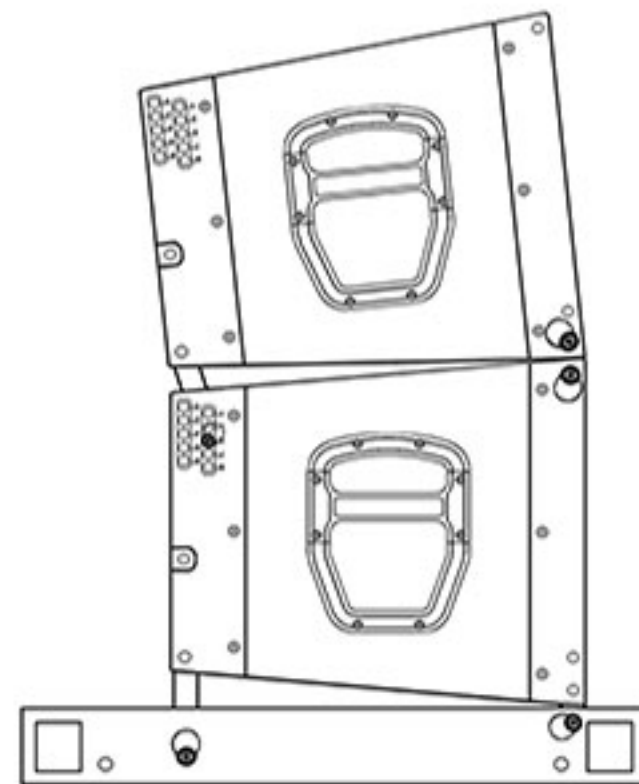

Modo estacado para la máxima versatilidad y cobertura / Stack mode for offer the maximum versatility and coverage.

IMPORTANTE: el uso incorrecto del marco y los componentes puede ser motivo de la formación de grietas que podrían poner en peligro la seguridad de un array. El uso de un cuadro y componentes dañados podría dar lugar a graves accidentes.

IMPORTANT: a misuse of the frame and components can be motive of cracking that could compromise the safety of an array. Using a damaged frame and components could result in serious mishaps.

V. SOFTWARE DE PREDICCIÓN Y HERRAMIENTAS DE INTEGRACION - PREDICTION SOFTWARE AND INTEGRATION TOOLS

En Pro DG Systems sabemos que fabricar cajas acústicas de buena calidad es una parte importante del trabajo. La garantía de poder utilizarlos adecuadamente, es la otra parte fundamental del trabajo que hemos realizado. Las buenas herramientas marcan la diferencia para lograr un óptimo uso de los sistemas.

GTA 1X12 L.A. dispone de Software de Predicción Ease Focus con el cual podemos simular el comportamiento de diferentes sistemas en distintos lugares y circunstancias además de poder como ver cobertura, frecuencia, SPL y comportamiento general del sistema, de una manera sencilla y cómoda para el usuario. Muy fácil de manejar y disponemos de cursos de entrenamiento para los usuarios de productos Pro DG Systems. Para más información consulte con nuestro servicio técnico en: info@prodgsystems.com

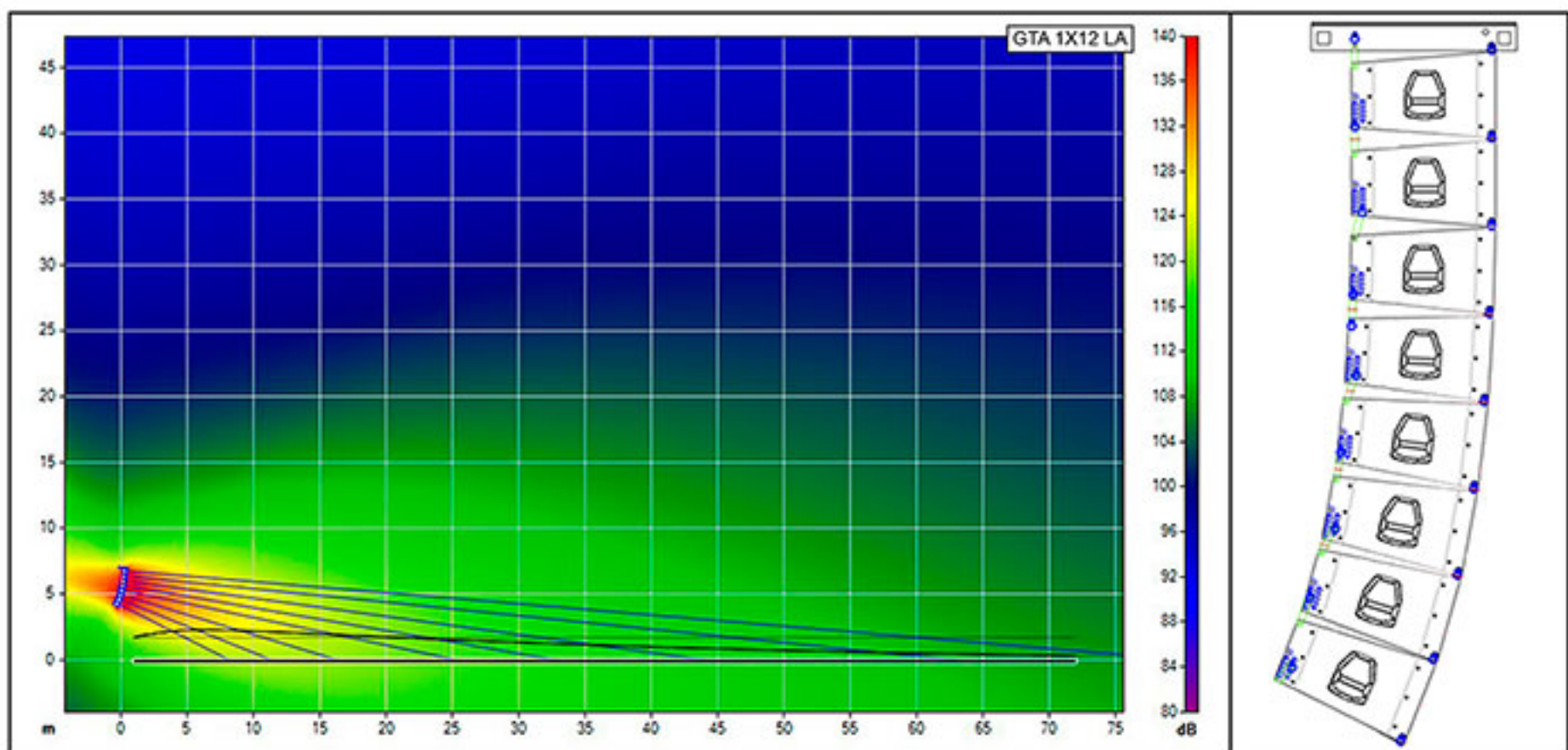

In Pro DG Systems we know that making good quality speakers is an important part of our job. Then, there is the other part that it is also fundamental in our job which is offering the warranty of using the speakers properly. Good tools make the difference to an optimal use of the system.

With the GTA 1X12 L.A. Prediction Software; Ease Focus we can design different configurations between systems and simulate their behavior in different places and circumstances, like watching coverage, frequency, SPL and general systems behavior in an easy and comfortable way. It is easy to handle and we offer training courses for Pro DG Systems customers. For more information consult with our technical service at: info@prodgsystems.com

VI. ACCESORIOS - ACCESSORIES

Pro DG Systems ofrece a sus clientes todo tipo de equipamiento y accesorios para sus sistemas. GTA 1X12 L.A. dispone de flight case de transporte o patín y funda para el transporte además de cableado completo del sistema listo para funcionar.

Pro DG Systems offers to their customers all type of accessories for their systems. GTA 1X12 L.A. has Flight Case for transport or Dolly Board and Covers for transport, plus complete cabling for the system ready to use.



Flight Case de transporte para cuatro unidades del GTA 1X12 L.A. Completamente dimensionado para el embalaje hermético y listo para la carretera.

Flight Case to transport 4 units of GTA 1X12 L.A. Fully dimensioned for an hermetic packaging and ready for the road.



Patin y funda para transportar cuatro unidades del GTA 1X12 L.A. Perfectamente dimensionado para el transporte en cualquier tipo de camión.

Dolly board and covers to transport four (4) units of GTA 1X12 L.A. Perfectly dimensioned to transport in any type of truck.



Disponibile cableado completo del sistema listo para funcionar.
Entire cabling for the system available and ready for operation.



PRO DG SYSTEMS INTERNATIONAL

Urbanización Ribera de San Luis 21
14500 Puente Genil (Córdoba)
ESPAÑA

Phone: + 34 954 011 095

Cell: + 34 607 290 698

E-mail: info@prodgsystems.com
export@prodgsystems.com

Web: www.prodgsystems.com

 SOMETHING IS CHANGING